

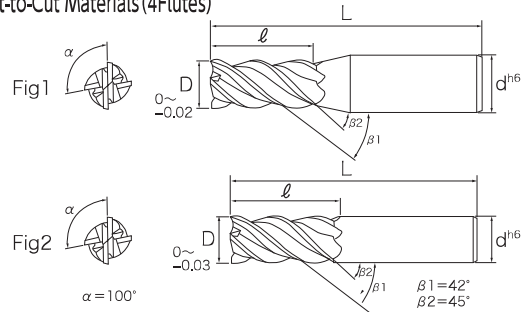

(ザ) カットミル 超硬4枚刃難削材用不等分割不等リードエンドミル

Unequal Division/Unequal Leads, Coated Solid Carbide Endmills for Difficult-to-Cut Materials (4Flutes)



特長 Feature

- 不等リード&独自刃型により難削材加工における切削抵抗とビブりを抑制
- Cutting resistance and chattering for difficult-to-cut materials are cut down due to a variable lead and original edge type.
- 高速切削が可能で美しい加工面を実現
- High speed cutting is possible and smooth machined surface is realized.
- 刃先は、ギャッシュランド採用(耐チッピング性能が向上)
- Gash land is used for cutting edge (chipping resistance improves).

商品コード Item Code	D	ℓ	L	d	Fig
IC4DMC-2.0	2	4	50	4	1
IC4DMC-3.0	3	7	50	6	1
IC4DMC-4.0	4	9	50	6	1
IC4DMC-5.0	5	12	50	6	1
IC4DMC-6.0	6	13	50	6	2

単位: mm

商品コード Item Code	D	ℓ	L	d	Fig
IC4DMC-8.0	8	19	60	8	2
IC4DMC-10.0	10	22	75	10	2
IC4DMC-12.0	12	26	75	12	2
IC4DMC-16.0	16	35	90	16	2
IC4DMC-20.0	20	45	100	20	2

標準切削条件表 (溝加工) Recommended cutting conditions (Slotting)

被削材 Work	炭素鋼/鋳鉄/合金鋼 S50C/FC250/SCM等(HRC30以下)		合金鋼/工具鋼 SKD61/SK/NAK等		ステンレス鋼/チタン合金 SUS304/SUS316		高硬度鋼 SKD61等(HRC45-55)		耐熱合金/インコネル等 Heat-resistant Steels Inconel Hasteloy	
	回転数 n(min ⁻¹)	送り速度 F(mm/min)	回転数 n(min ⁻¹)	送り速度 F(mm/min)	回転数 n(min ⁻¹)	送り速度 F(mm/min)	回転数 n(min ⁻¹)	送り速度 F(mm/min)	回転数 n(min ⁻¹)	送り速度 F(mm/min)
2	15,300	610	9,000	360	8,650	280	4,300	120	2,900	70
3	10,800	650	6,200	370	6,700	340	2,900	130	2,400	100
4	8,300	730	5,000	440	5,100	360	2,200	135	1,800	115
5	6,850	960	4,050	560	4,100	370	1,700	150	1,500	130
6	5,800	1,150	3,400	650	3,400	380	1,450	170	1,200	140
8	4,300	1,030	2,500	580	2,600	350	1,100	170	900	130
10	3,400	820	2,000	480	2,000	320	900	155	720	120
12	2,900	720	1,700	410	1,750	270	720	135	600	100
16	2,200	610	1,300	350	1,300	250	540	120	450	75
20	1,700	550	1,000	320	1,000	230	430	110	360	55
切込み量 Depth of cut	ae=1D, ap=1D				ae=1D, ap≤0.5D		ae=1D, ap≤0.2D			

標準切削条件表 (側面加工) Recommended cutting conditions (Side cutting)

☆ap<1.5D ☆調質鋼加工時 ae<0.02D ap≤1D
Thermal refining steels

被削材 Work	炭素鋼/鋳鉄/合金鋼 S50C/FC250/SCM等(HRC30以下)		合金鋼/工具鋼 SKD61/SK/NAK等		ステンレス鋼/チタン合金 SUS304/SUS316		高硬度鋼 SKD61等(HRC45-55)		耐熱合金/インコネル等 Heat-resistant Steels Inconel Hasteloy	
	回転数 n(min ⁻¹)	送り速度 F(mm/min)	回転数 n(min ⁻¹)	送り速度 F(mm/min)	回転数 n(min ⁻¹)	送り速度 F(mm/min)	回転数 n(min ⁻¹)	送り速度 F(mm/min)	回転数 n(min ⁻¹)	送り速度 F(mm/min)
2	19,000	1,000	15,200	800	12,600	500	8,700	280	4,300	120
3	13,500	1,150	10,800	920	9,540	700	6,700	340	3,600	180
4	10,000	1,300	8,000	1,040	7,200	850	5,100	370	2,900	200
5	8,200	1,700	6,600	1,360	5,800	920	4,000	390	2,250	230
6	6,700	2,000	5,400	1,600	4,800	950	3,200	400	1,900	230
8	5,200	1,600	4,200	1,280	3,600	860	2,500	405	1,400	240
10	4,300	1,300	3,400	1,040	2,900	750	2,000	400	1,200	250
12	3,600	1,150	2,900	920	2,450	630	1,600	360	1,000	160
16	2,700	1,000	2,200	800	1,800	510	1,200	300	720	120
20	2,200	800	1,800	640	1,500	460	1,000	280	540	100
切込み量 Depth of cut	ae≤0.2D, ap≤1.5D				ae≤0.1D, ap≤1.5D		ae≤0.05D, ap≤1.5D			

※切削条件はあくまでも目安です。使用される機械、チャックの剛性や切削油等の状況によって変動致します。

These conditions are for general guidance. Therefore they are subject to change to the situation of the machine used, the tool hold rigidity, cutting oil, etc.

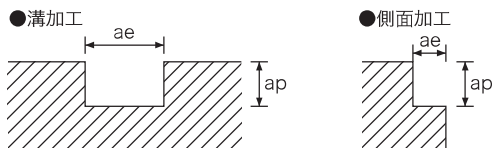

構造用鋼/炭素鋼 (SS41, S45C)	工具鋼/プリハードン鋼 (SKD, NAK101)	合金鋼/ステンレス鋼 (SCM, SUS304)	チタン合金/耐熱合金 Titanium alloy Heat-resistant alloy	硬質材 Hard material
HRC30以下	HRC30~35	HRC35~40		HRC45~55
○	○	◎	◎	○