

生爪用 Tナット

Tナット(ジョーナット)

T-nut for SOFT JAWS

[3個1組 Set of Three]

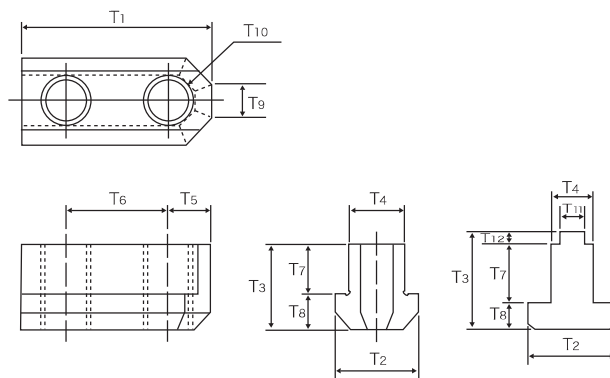

特長 Feature

●高品質・低価格・安定供給

●High quality, Low price, Stable supply.

Tナット(ジョーナット) T-nut for SOFT JAWS 材質:S50C(HRC33~38)

単位: mm

チャックメーカー Manufacturer	サイズ Size	商品コード Item Code	T1	T2	T3	T4	T5	T6	T7	T8	T9	T10	T11	T12	重量 kg
豊和 HOWA	6	TN-6HN	37	17	21.5	12	8	20	14	7.5	6	M10	-	-	0.2
	※1 8	TN-8HN	46	20	23.5	14	10	25	15	8.5	8	M12	-	-	0.3
	※1※3 10	TN-10H	51	23	23.5	16	10	30	15	8.5	8	M12	-	-	0.4
	※1 12	TN-12H	53	28	33	18	11	30	19	14	12	M14	-	-	0.7
	※1 15,18,21,24	TN-15H	82	34	40	26	16	50	23	17	16	M20	-	-	1.6
	※1 8	TN-8HO37M	45	22	26.5	16	10	25	18	8.5	8	M12	-	-	0.4
	※1 10	TN-10HO37M	52	24	27.5	18	11	30	18	9.5	10	M14	-	-	0.5
	※1 12	TN-12HO37M	60	27	29	21	12	35	18.5	10.5	12	M16	-	-	0.7
北川 KITAGAWA	4	TN-N-04	26	14.5	18	10	6	14	12.5	5.5	5	M8	-	-	0.2
	5	TN-B-05	30	14	15.5	10	6	18	10	5.5	5	M8	-	-	0.2
	5	TN-N-05	32	14.5	18	10	6	19	12.5	5.5	6	M8	-	-	0.2
	6	TN-6KN	36.5	17	22.5	12	8	20	15	7.5	6	M10	-	-	0.2
	8	TN-8KN	48	20	25.5	14	11	25	16	9.5	8	M12	-	-	0.3
	10	TN-10KN	55	22	25.5	16	11	30	16	9.5	8	M12	-	-	0.5
	12	TN-12KN	55.5	26.5	33.5	18	11.5	30	20	13.5	12	M14	-	-	0.7
	15,18	TN-B-15/18	80	33.5	45.5	24	17	43	20.8	16.5	11	M20	22	8.2	1.6
	21,24	TN-B-21/24	100	37.5	45	25	20	60	26	19	16	M20	-	-	2.4
	B204,B205	TN-B204/205K	26	14.5	15	10	6	14	9.5	5.5	5	M8	-	-	0.2
	B206	TN-B206KN	36.5	17	18.5	12	8.25	20	11	7.5	8	M10	-	-	0.2
	B208	TN-B208KN	46.5	20	20.5	14	10.5	25	12	8.5	12	M12	-	-	0.3
	B210	TN-B210KN	51	22	21.5	16	11	30	13	8.5	11	M12	-	-	0.4
※2 B212	TN-B212KN	55.5	29.5	27.75	21	12	30	16.25	11.5	13	M16	-	-	0.6	
BB212	TN-BB212K	56.25	29.5	22.75	21	12	30	11.25	11.5	9.5	M16	-	-	0.6	
B215	TN-B215K	80	35	39.25	25.5	17	43	20.25	19	14	M20	-	-	1.6	
松本 MATSUMOTO	6	TN-6MN	40	17.5	20	11	7.5	25	12.5	7.5	7	M8	-	-	0.2
	※3 8	TN-8M	45	20	23	14	10	25	14.5	8.5	8	M12	-	-	0.3
	10	TN-10MN	50	23	23	16	10	30	15	8	15	M12	-	-	0.4
日鋼 NIKKO	6	TN-6NN	41	13.5	14.5	11	8	25	8	6.5	7	M8	-	-	0.2
	8	TN-8NN	50	19	15.5	14	10	30	9	6.5	9	M10	-	-	0.3
	10	TN-10NN	51	26	21	20	11	30	12.5	8.5	14	M12	-	-	0.5

※1 TN-8HN・10H・12H・15HはHO1MA用で、TN-8HO37M,10HO37M,12HO37MはHO37M用です。HO22M用は製作しておりません。

※2 TN-B212KNはBB212のチャックには対応しておりません。(T1,T3,T7,T9寸法が異なります。)新たにBB212対応のTナット「TN-BB212K」を製作致しました。

※3 無くなり次第、後継品の「N」付きに移行いたします。

※1 TN-8HN, 10H, 12H, and 15H are for HO1MA, and TN-8HO37M, 10HO37M, and 12HO37M are for HO37M. Not made for HO22M.

※2 TN-B212KN is not compatible with BB212 chuck. (due to different T1, T3, T7, T9 size) Newly produced "TN-BB212K" for BB212.

※3 As soon as we run out, we will shift to the alternative product with an "N" at the end.

Tナット チャック対応表 T-nut for SOFT JAWS Chuck Correspondence table

チャックメーカー Manufacturer	Tナット型式 Model No.	対応チャック型式 Corresponding chuck models
豊和 HOWA	TN-6HN	H01MA6, 6S, 6 A5-J, H022M6, H023M8, H024M6, H027M6, H034M6, H047M6, H037M6 H05M6, H032M8, H012D6
	TN-8HN	H01MA8, 8S
	TN-10H	H01MA10, 10S
	TN-12H	H01MA12, 12S
	TN-15H	H01MA15,18, 21, 24
	TN-8HO37M	H037M8, H022M8, H023M10, H024M8, H027M8, H034M8, H047M8, H05M8, H032M10, H012D8
	TN-10HO37M	H037M10, H022M10, H023M12, H024M10, H027M10, H034M10, H047M10, H05M10, H032M12, H012D10
	TN-12HO37M	H037M12, H027M12, H034M12, H047M12
北川 KITAGAWA	TN-N-04	N-04, NT04, NL04, AS04, AT04, NRC04, (HJ-4)
	TN-B-05	(B-05, BT05, HOB-5, HOBT-5)
	TN-N-05	N-05, NT05, (HJ-5)
	TN-6KN	N-06, (NT06, HJ-6), NL06, NLT06, AS06, AT06, NRC06, B-06, BT06, (HO-6,HOH-06K), HO-6
	TN-8KN	N-08, (NT08, HJ-8), NL08, NLT08, AS08, AT08, NRC08, B-08, BT08, HOH-08K, HO-8
	TN-10KN	N-10, (NT10, HJ-10), NL10, NLT10, AS10, AT10, NRC10, HW-10, HW-12, B10, BT10, HOH-10K, HO-10
	TN-12KN	N-12, (NT12, HO-12A), NL12, NLT12, B-12, BT12, HO-12A
	TN-B204/205K	B-204, BT204, B-205, BT205
	TN-B206KN	HW-08, B-206, BB206, BS306, BT206, HOH-206, BL206, BLT206, BR06(通常Tナット)㊦
	TN-B208KN	B-208, BB208, BS308, BT208, HOH-208, BL208, BLT208, BR08(通常Tナット)㊦
	TN-B210KN	B-210, BB210, BS310, BT210, BL210, BLT210, BR10(通常Tナット)㊦
	TN-B212KN	B-212, BT212, BL212, BLT212
	TN-BB212K	BB212, BR12(通常Tナット)㊦
	TN-B-15/18	B-15,BT15,B-18,(HOB-15,HOBT-15,HOH-15,HO-15,HLA8-18,HJA11-15)
TN-B215K	B-215, N-15, N-18	
TN-B-21/24	B-21・24(HOB-21・24)ソフトジョー用, N-21, N-24	
松本 MATSUMOTO	TN-6MN	H-6-34, HA-5-6-34, HH-6, HHA5-6
	TN-8M	H-8-46, HA-6-8-46, HH-8, HHA6-8, HXA6-8-46
	TN-10MN	H-10-67, HA-6-10-50, HH-10, HHA6-10, HHA8-10, HXA8-10-67
日鋼 NIKKO	TN-6NN	HF6, HDM165, MO6, GO6, GO-6S, PDM6, COP7, HWB165
	TN-8NN	HF8, HDM215, MO8, GO8, GO-8S, COP8, HWB205, HWB215, PDM8
	TN-10NN	HF10, MO10, GO10, HDM250, COP12, HWB250

※ ()内のチャック型式は旧型式となります。 Chuck models in parentheses are old models.

㊦北川高精度チャックBRシリーズ用の特殊Tナット-Plusとは異なり、通常精度のTナットです。

Unlike the special T-nut "Tnut-Plus" for the KITAGAWA high-precision chuck BR series, this is a normal precision T-nut.